



LITHIUM BATTERY MODULE

USER MANUAL

ES100



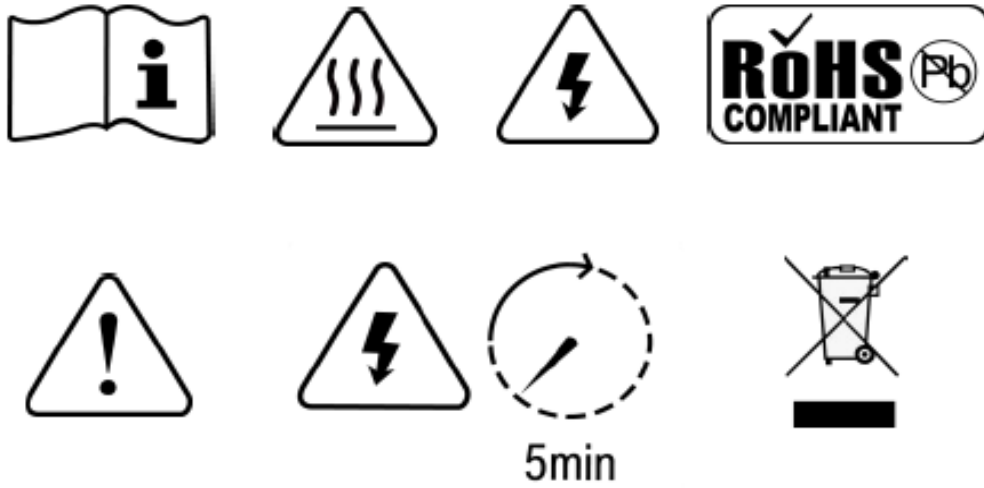

WARNING:HIGH VOLTAGE IN SIDE

CAUTION:THE DC FUSE MUST HAVE BEEN TURNED OFF BEFORE SERVICING

MADE IN CHINA

Statement of Law

Copyright of this document belongs to TBB Power Co., Ltd. No part of this documentation maybe excerpted, reproduced, translated, annotated or duplicated in any form or by any means without the prior written permission of TBB Power Co., Ltd. All Rights Reserved.

This product complies with the design requirements of environmental protection and personal safety. The storage, use and disposal of the products shall be carried out in accordance with the product manual, relevant contract or relevant laws and regulations.

Customer can check the related information on the website of TBB Power Co., Ltd when the product or technology is updated. Web URL:

[http:// www.tbbpower.com/](http://www.tbbpower.com/)

Please note that the product can be modified without prior notice.

Safety Precautions



Warning

- Please do not put the battery into water or fire, in case of explosion or any other situation that might endanger your life.
- Please connect wires properly while installing the battery, do not reverse connect. To avoid short circuit, please do not connect positive and negative poles with conductor (Wires for instance).
- Please do not stab, hit, trample or strike the battery in any other way.
- Please shut off the power completely when removing the device or reconnecting wires during the daily use or it could cause the danger of electric shock.
- Please use dry powder extinguisher to put out the flame when encountering a fire hazard, liquid extinguisher could result in the risk of secondary disaster.
- For your safety, please do not arbitrarily dismantle any component in any circumstances unless a specialist or an authorized one from our company, device breakdown due to improper operation will not be covered under warranty.



Caution

- We have strict inspection to ensure the quality when products are shipped out, however, please contact us if case bulging or another abnormal phenomenon.
- For your safety, device shall be ground connected properly before normal use.
- To assure the proper use please make sure parameters among the relevant device are compatible.
- Please do not mixed-use batteries from different manufacturers, different types and models, as well as old and new together.
- Ambient and storage method could impact the life span and product reliability, please consider the operation environment abundantly to make sure device works in proper condition.
- For long-term storage, the battery should be recharged once every 6 months, and the amount of electric charge shall exceed 80% of the rated capacity.
- Please charge the battery in 18 hours after it discharges fully and starts over-discharging protection. Formula of theoretical standby time: $T=C/I$ (T is standby time, C is battery capacity, I is total current of all loads).

Preface

Manual declaration

The ES100 lithium iron phosphate battery can be widely applied to energy storage systems including backup power, solar off grid, solar energy storage, solar hybrid, PV power generation, etc.

This user manual details its basic structure, parameters, basic procedures and ways of installation and operation and maintenance of the equipment.

Contents

1. Introduction	1
1.1 Brief Introduction	1
1.2 Product Properties	1
1.3 Product identity definition	2
2. Product Specification	3
2.1 Size and Weight	3
2.2 Performance Parameter	4
2.2.1 Front Panel Interface Definition	4
2.2.2 Address	5
2.2.3 Communication Port Definition	7
2.2.4 SOC light display and corresponding battery capacity	7
2.3 Battery Management System (BMS)	8
2.3.1 Voltage Protection	8
2.3.2 Current Protection	8
2.3.3 Temperature Protection	8
2.3.4 Other Protection	8
3. Installation and Configuration	9
3.1 Ready for installation	9
3.1.1 Environmental requirements	9
3.1.2 Tools and data	10
3.1.3 Technical preparation	10
3.1.4 Unpacking inspection	11
3.1.5 Engineering coordination	12
3.2 Equipment installation	12
3.2.1 Installation preparation	13
3.2.2 Mechanical installation	13
3.2.3 Electrical installation	15
4. Use, maintenance and troubleshooting	16
4.1 Battery system usage and operation instructions	16
4.2 Alarm description and handling	17
4.3 Analysis and treatment of common faults	17
4.4 Recycle and disposal	17

1. Introduction

1.1 Brief Introduction

ES100 lithium iron phosphate battery system is a standard battery system unit. Customers can choose a certain number of ES100 according to their needs, to form a larger capacity battery storage through parallel connection, to meet the user's long-term power supply needs. The product is especially suitable for applications with high operating temperatures and limited installation space, requiring long power backup time and long service life.

1.2 Product Properties

ES100 energy storage product's anode materials are lithium iron phosphate. Battery cells are managed effectively by BMS with better performance. The system's features are shown below:

- Suitable for applications with a rated voltage of 48V
- Built-in battery management system for better performance, possessing protection functions like over-discharge protection, over-charge protection, over-current protection, abnormal temperature protection.
- Support up to 32 modules in parallel to prolong the standby time.
- Support parameter configuration and data monitoring via TBblink software.
- Support CAN communicate with mainstream inverters, like TBB inverter/Victron inverter.
- Self-ventilation with lower system noise
- Less battery self-discharge, during storage, its power can be self-discharged for 6 months at max until it is recharged
- No memory effect so that battery can be charged and discharged shallowly.
- Wide range of temperature for working environment, $-20^{\circ}\text{C} \sim +55^{\circ}\text{C}$. Circulation span and discharging performance are well under high temperature.
- Less volume, lighter weight.

1.3 Product identity definition

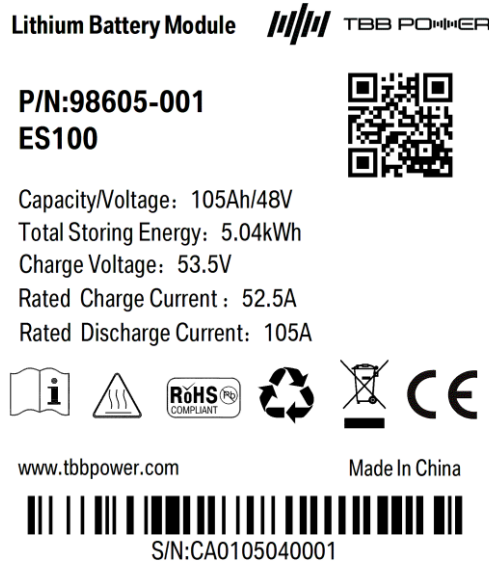















Figure 1-1 Battery Energy Storage System nameplate

	Battery voltage is higher than safe voltage, direct contact with electric shock hazard.
	Be careful with your actions and be aware of the dangers.
	Read the user manual before using.
	The scrapped battery cannot be put into the garbage can and must be professionally recycled.
	After the battery life is terminated, the battery can continue to be used after it recycled by the professional recycling organization and do not discard it at will.
	This battery product meets European directive requirements.
<div style="background-color: red; color: white; padding: 5px; text-align: center;"> DANGER <small>HIGH VOLTAGE INSIDE</small> </div>         <ul style="list-style-type: none"> Do not disconnect, disassemble or repair by yourself. Do not drop, deform, impact, cut or spearing with a sharp object. Do not place near open flame or incinerate. Do not sit or put heavy things on battery. Keep away from moisture or liquid. Keep out of reach of children, animals or insects. Contact the supplier with 24 hours if anything wrong. <p>Emergency Situations</p> <ul style="list-style-type: none"> If leaking, fire, wet or damaged, switch off the breaker and go away from the battery. Do not touch the leaking liquid. Do not use water, sand or dry powder extinguisher is usable. 	Dangerous goods warning label on the right of the battery module.

2. Product Specification

2.1 Size and Weight

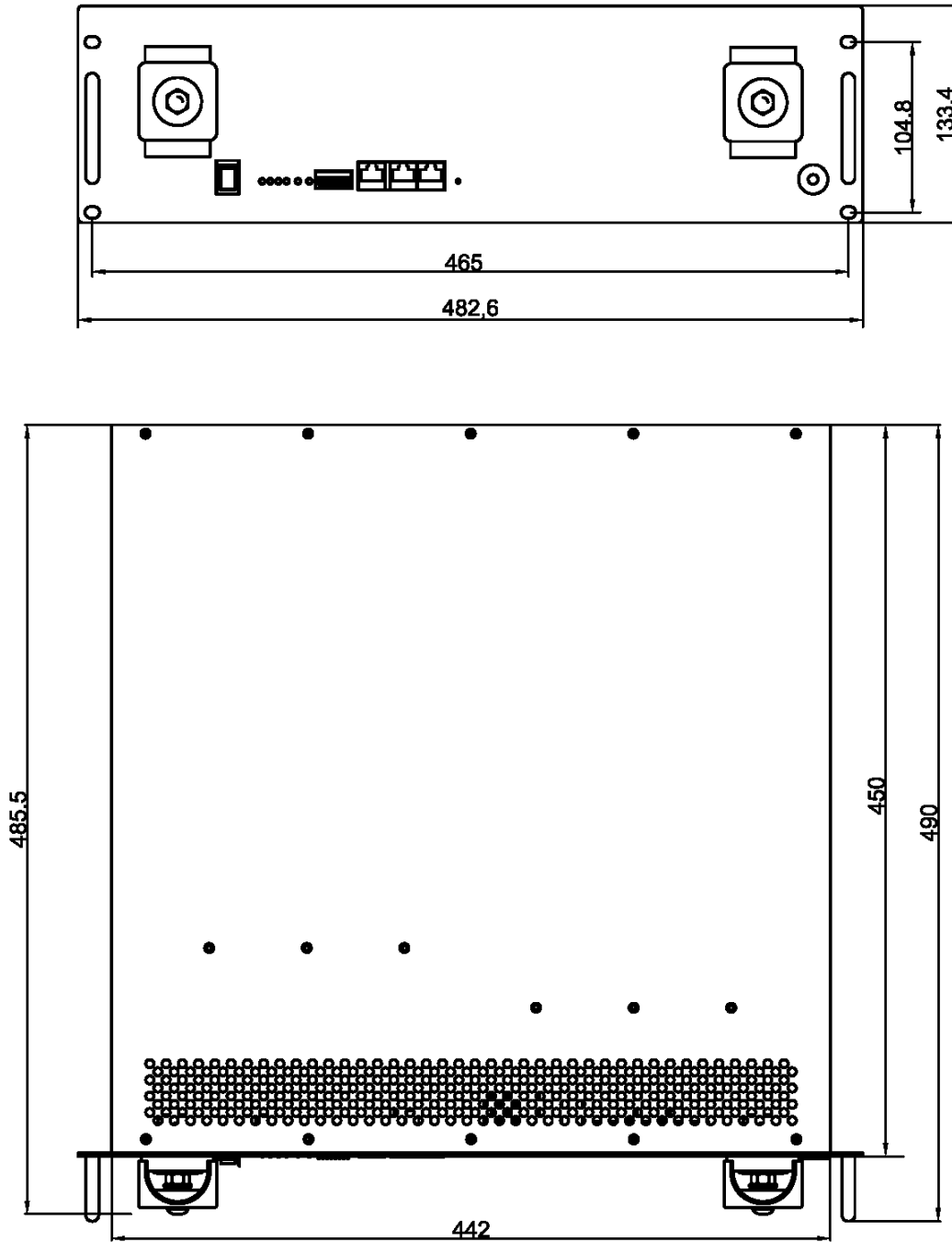

Table 2-1 ES100 Device size

Product	Nominal Voltage	Nominal Capacity	Dimension	Weight
ES100	DC48V	105Ah	482.6×450×133.4mm	40kg

2.2 Performance Parameter

Table 2-2 ES100 performance parameter

Item	ES100
Configuration	15S1P
Nominal Voltage (V)	48
Nominal Capacity (Ah)	105
Nominal Energy (kWh)	5.04
Standard charge current (A)	50
Maximum charge current (A)	105
End of charging current (A)	1.5
Standard charge voltage(V)	53.5
Max. charge voltage(V)	54.75
Standard discharge current (A)	52.5
Maximum discharge current (A)	105
Final discharge voltage(V)	42
Cycle Life	90%DOD, 6000 cycles life
Charging temperature range	0°C~+55°C
Discharging temperature range	-20°C~+55°C
Storage temperature	-20°C~+45°C 1month 0°C~+35°C 3months

2.2.1 Front Panel Interface Definition

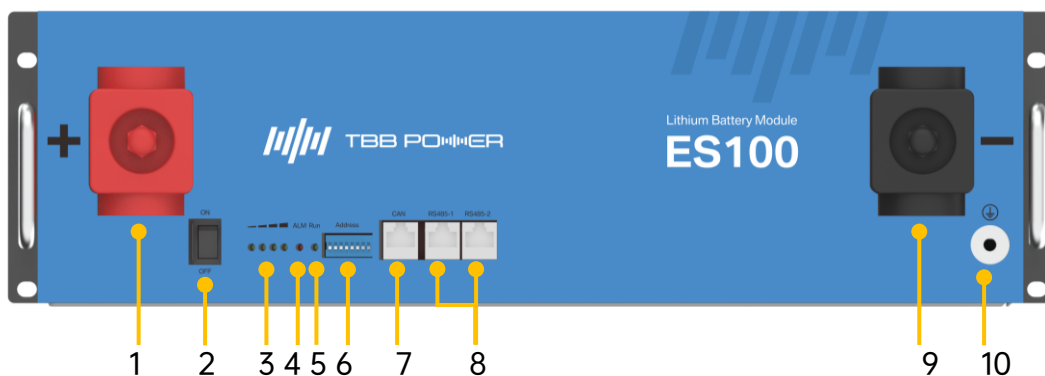
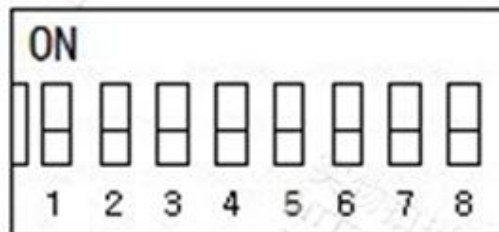

Figure 2-2 The interface of ES100

Table 2-3 Interface Definition

Item	Name	Definition
1	Positive socket	Connect to battery positive output cable or positive parallel cable
2	Power switch	OFF/ON button, must be on the "ON" state when in use
3	SOC	The number of green lights on shows the remaining battery power. See Table 2-6 for details.
4	ALM	Red light flashes when an alarm occurs. Red light is always on during protection status. After the protection is released, it can be automatically closed.
5	Run	Green light flashes during standby and charging mode. Green light is always on when the battery is under discharging.
6	Address	DIP switch
7	CAN	Communication cascade port, support CAN
8	RS485	Communication cascade port, support 485
9	Negative socket	Connect to battery negative output cable or parallel negative cable
10	Ground connection point	Shell ground connection

2.2.2 Address



DIP switch bit1 to bit8 definition: bit1~bit5 is used to set the slave address or the number of slaves in parallel according to the master and slave status; bit8 is used to set the mark of the master and slave; bit6~bit7 are reserved bits.

Slave setting: bit1~bit5 are used to set the slave address. According to the device sequence, the slave address range is from 1 to 31. bit8 is fixed to OFF. Please refer to the slave setting table for detailed dialing code.

Host setting: bit1~bit5 are used to set the number of slaves in parallel. bit8 is fixed to ON. Please refer to the host setting table for detailed dialing code.

When the battery packs are connected in parallel, the master battery and the slave battery can communicate with each other through the RS485 interface, to get the information of the entire battery system. The battery can communicate with the inverter via CAN interface.

Table 2-4 Slave setting

Address	DIP switch					Description
	#1	#2	#3	#4	#5	
1	ON	OFF	OFF	OFF	OFF	Address 1
2	OFF	ON	OFF	OFF	OFF	Address 2
3	ON	ON	OFF	OFF	OFF	Address 3
4	OFF	OFF	ON	OFF	OFF	Address 4
5	ON	OFF	ON	OFF	OFF	Address 5
6	OFF	ON	ON	OFF	OFF	Address 6
7	ON	ON	ON	OFF	OFF	Address 7
8	OFF	OFF	OFF	ON	OFF	Address 8
...
28	OFF	OFF	ON	ON	ON	Address 28
29	ON	OFF	ON	ON	ON	Address 29
30	OFF	ON	ON	ON	ON	Address 30
31	ON	ON	ON	ON	ON	Address 31

Table 2-5 Master setting

Slave Quantity	DIP switch						Description
	#1	#2	#3	#4	#5	#8	
1	ON	OFF	OFF	OFF	OFF	ON	2 pcs in parallel
2	OFF	ON	OFF	OFF	OFF	ON	3 pcs in parallel
3	ON	ON	OFF	OFF	OFF	ON	4 pcs in parallel
4	OFF	OFF	ON	OFF	OFF	ON	5 pcs in parallel
5	ON	OFF	ON	OFF	OFF	ON	6 pcs in parallel
6	OFF	ON	ON	OFF	OFF	ON	7 pcs in parallel
7	ON	ON	ON	OFF	OFF	ON	8 pcs in parallel
8	OFF	OFF	OFF	ON	OFF	ON	9 pcs in parallel
...
28	OFF	OFF	ON	ON	ON	ON	29 pcs in parallel
29	ON	OFF	ON	ON	ON	ON	30 pcs in parallel
30	OFF	ON	ON	ON	ON	ON	31 pcs in parallel
31	ON	ON	ON	ON	ON	ON	32 pcs in parallel

2.2.3 Communication Port Definition

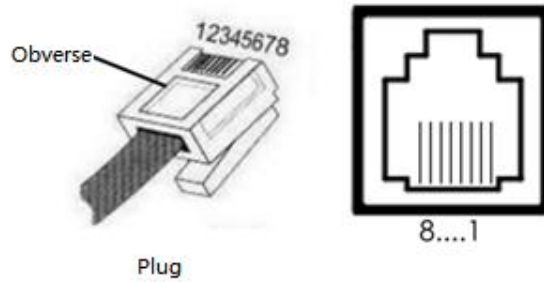

The product provides three RJ45 connectors respectively for one CAN port and two RS485 communication ports. All pins of the two connectors RS485-1 and RS485-2, are connected in parallel, so their interface definitions are completely the same. Table 2-6 defines the pins of each interface.

Table 2-6

Port	Description
CAN	PIN4:CANH
	PIN5:CANL
	PIN1、3、8:NC
	PIN2、6、7:NC
RS485-1	PIN2、7:485-1A
	PIN1、3、8:485-1B
	PIN6:485-2A
	PIN5:485-2B
RS485-2	PIN2、7:485-1A
	PIN1、3、8:485-1B
	PIN6:485-2A
	PIN5:485-2B

2.2.4 SOC light display and corresponding battery capacity

Table 2-7

Status	Charging				Discharging			
	L1	L2	L3	L4	L1	L2	L3	L4
Capacity indicator	L1	L2	L3	L4	L1	L2	L3	L4
0~25%	flashing	OFF	OFF	OFF	ON	OFF	OFF	OFF
25~50%	ON	flashing	OFF	OFF	ON	ON	OFF	OFF
50~75%	ON	ON	flashing	OFF	ON	ON	ON	OFF
75~100%	ON	ON	ON	flashing	ON	ON	ON	ON
Running indicator	ON				flashing			

2.3 Battery Management System (BMS)

2.3.1 Voltage Protection

Low Voltage Protection during Discharging Process:

When the voltage of a battery cell or the total voltage is lower than the protection value, the battery will start over-discharging protection during the discharging process and the battery ALM indicator will be always on. Then the battery system will stop supplying power to the loads. The protection will end when the voltage is restored to the rated return range.

Over Voltage Protection during Charging Process:

When the total voltage or a battery cell voltage reaches the protection value during the charging process, the battery ALM indicator will be always on, and the battery will stop charging. The protection will end when either the total voltage or the voltage of any battery cell is restored to the rated return voltage range.

2.3.2 Current Protection

Over Current Protection during Charging Process:

When the battery pack is not equipped with a charging current limiting module or the charging current limiting function is disabled, the BMS should have a charging over-current protection function. Try the protection and recovery every 5 minutes. If the charging is still over-current, it will be protected again. If the charging is not over-current, it should be automatically protected and recovered.

Over Current Protection during Discharging Process:

When the discharge current is greater than the protection value, the system will stop supplying power to the loads, and disable the output. The BMS detects whether there's discharging over-current every 1 minute. If there is no discharging over-current, it will be restored to the standby state. If there is discharging over-current, it will continue the protection. Also, it can resume normal operation by charging.

2.3.3 Temperature Protection

Less/Over Temperature Protection during Charging Process:

When battery's temperature is beyond range of 0 °C ~+55 °C during charging, the temperature protection will start, and the device will stop the charging process.

Less/Over Temperature Protection during Discharging Process:

When battery's temperature is beyond range of -20°C~+55°C during discharging, the temperature protection will start, and the battery will stop its output.

2.3.4 Other Protection

Short Circuit Protection:

If the battery is activated in the off state, the short-circuit protection will be triggered. Detect if there is an external short-circuit every 5 seconds and turn on the pre-charging. If there is no short-circuit, it will be restored to the standby state. If there is still a short-circuit, the protection will be continued. After 5 consecutive short-circuit detections, the detection will be ended and the normal output function is no longer automatically restarted. It can only be restored by manual reset or charging after the fault is eliminated.

Sleep mode:

When the battery does not supply power to the load or connect to any power source, and there is no external communication for more than 48 hours, the battery will automatically enter the standby sleep mode.

3. Installation and Configuration

3.1 Ready for installation

Safety Requirement

This system can only be installed by personnel who have been trained on the power supply system and have sufficient knowledge of the power system.

The safety regulations and local safety regulations listed below should always be followed during the installation.

- All circuits connected to this power system with an external voltage of less than 48V must meet the SELV requirements defined in the IEC60950 standard.
- If operating within the power system cabinet, make sure the power system is not charged. Battery devices should also be switched off.
- Distribution cable wiring should be reasonable and has the protective measures to avoid touching these cables while operating power equipment.
- The following protective equipment must be worn when installing the battery system:



Protective gloves



Safety goggles



Protective shoes

Figure 3-1

3.1.1 Environmental requirements

- Working temperature: $-20^{\circ}\text{C}\sim 55^{\circ}\text{C}$
- Charging temperature range is $0^{\circ}\text{C}\sim 55^{\circ}\text{C}$
- Discharging temperature range is $-20^{\circ}\text{C}\sim 55^{\circ}\text{C}$
- Storage temperature: $0^{\circ}\text{C}\sim 35^{\circ}\text{C}$
- Relative humidity: 15%~90%
- Elevation: 86 kPa-106 kPa

Operating environment: It needs to be installed indoors. The installation location needs to be protected from sunlight, no wind, no conductive dust and no corrosive gas.

And the following conditions should be met:

- Installation location should be away from the sea to avoid brine and high humidity environment.
- The ground is flat and horizontal.
- There are no flammable explosive articles near to the installation places.
- The optimal ambient temperature is $15^{\circ}\text{C} \sim 30^{\circ}\text{C}$.
- Keep away from dust and messy zones.

3.1.2 Tools and data

Hardware tool

Tools and meters that may be used are shown in table 3-1.

Table 3-1 Tool instrument

Name	
Screwdriver (word, cross)	AVO meter
Wrench	Clamp meter
Inclined pliers	Insulating tape
Needle nose pliers	The thermometer
Clip forceps	Wrist strap
Wire stripper	Tape
Electric drill	

3.1.3 Technical preparation

Electrical interface check

Devices that can be connected directly to the battery can be user's equipment, power supplies, or other power sources.

- Confirm whether the user's PV power generation equipment, power supply or other power supply equipment has a DC output interface, and measure whether the DC power output voltage meets the voltage range requirements in Table 2-2.
- Confirm that the maximum discharge current capability of the DC power interface of the user's PV power generation equipment, power supply or other power supply equipment is greater than the maximum charging current of the products used in Table 2-2.

If the maximum discharge capacity of the DC power interface of the user's PV power generation equipment is less than the maximum charging current of the products used in Table 2-2, the DC power interface of the user's PV power generation equipment shall have a current limiting function to ensure the normal operation of the user's equipment.

- Verify that the maximum operating current of the battery-powered user equipment (inverter DC input) is less than the maximum discharge current of the products used in Table 2-2.

The security check



- Firefighting equipment should be provided near the equipment, such as portable dry powder fire extinguisher.
- Automatic fire fighting system shall be provided for the case where necessary.
- No flammable, explosive and other dangerous articles are placed beside the battery.

3.1.4 Unpacking inspection

- When the equipment arrives at the installation site, loading and unloading should be carried out according to the rules and regulations, to prevent it from being exposed to sun and rain.
- Before unpacking, the total number of packages shall be indicated according to the shipping list attached to each package, and the case shall be checked for good condition.
- In the process of unpacking, handle it carefully and protect the surface coating of the object.
- Open the package, the installation personnel should read the technical documents, verify the list, according to the configuration table and packing list, ensure objects are complete and intact. If the internal packing is damaged, it should be examined and recorded in detail.

Packing list is as follows:

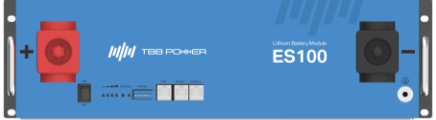
Table 3-2

Item	Specification	Quantity	Figure
Battery ES100	48V/105Ah 482.6×450×133.4mm	1	
Parallel copper bars	Orange /L165mm (Hole Center Distance)	2	
Communication parallel cable	Black /L300mm/Double RJ45 plug	1	
Communication cable-to inverter	Black /L2000mm /Double RJ45 plug	1	
Ground wire	L200mm,4mm ²	1	
User Manual	User manual	1	
Screw	Crown Screws M6*19	4	

3.1.5 Engineering coordination

Attention should be paid to the following items before construction:

➤ Power cable specification.

The power cable specification shall meet the requirements of maximum discharge current for each product.

➤ Mounting space and bearing capacity.

Make sure that the battery has enough room to install, and the battery rack and bracket have enough load capacity.

➤ Wiring

Make sure the power cables and ground wires are installed reasonably, to prevent them from being short-circuited, flooded, and corroded.

3.2 Equipment installation

Table 3-3 Installation steps

Step1	Installation preparation	Confirm that the ON/OFF switch on the front panel of battery is in the "OFF" state to ensure no live operation.
Step 2	Mechanical installation	1. Cabinet placement position determination
		2. Pre-install the top cable harness
		3. Battery module installation
Step3	Electrical installation	1. Ground cable installation
		2. Battery module parallel cables installation
		3. Battery module all positive cables installation
		4. Battery module all negative cable installation
		5. Internal CAN communication interface connection
Step4	Battery system self-test	1. Press the ON/OFF switch to the "ON" state
		2. BMS system power-on activation
		3. Check the system output voltage
		4. Shut down the system
Step5	Connecting inverter	1. Connect all positive & all negative cables of the battery system to the inverter
		2. Connect the external CAN communication cable to the inverter

3.2.1 Installation preparation

1. Prepare equipment and tools for installation.
2. Check the battery and confirm that the ON/OFF switch is in the "OFF" state to ensure no live operation.

3.2.2 Mechanical installation

Installation method 1: With Cabinet installation

1. Place the battery cell on the cabinet bracket as shown in the figure and push it into the installation position of the cabinet. (The cabinet structure in the figure is for reference only)

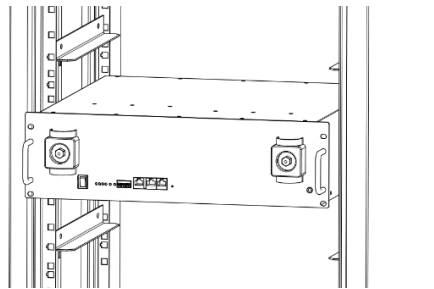

Figure 3-2

2. Secure the battery cell on the cabinet with a nut through the mounting holes on the top of the battery hanging ears.

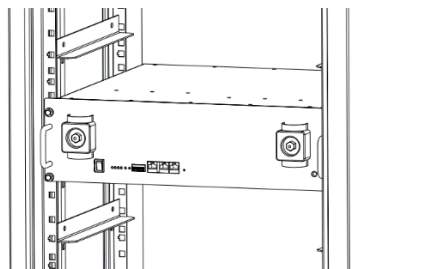

Figure 3-3

Installation method 2: With Simple bracket installation

1. Place the battery and a bracket as shown in the figure3-4, and insert the battery into the bracket.

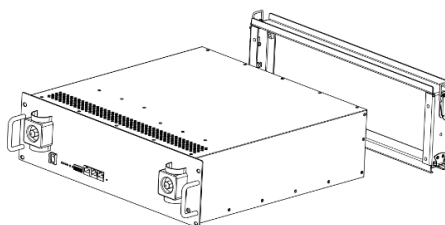

Figure 3-4

2. Complete insert the battery into the bracket as figure3-5, pay attention to pushing the battery to the buckle position.

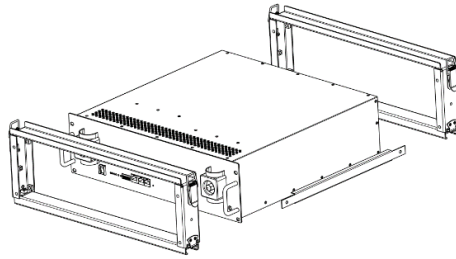

Figure 3-5

3. Place another bracket in the rear of the battery and push it to the buckle position.

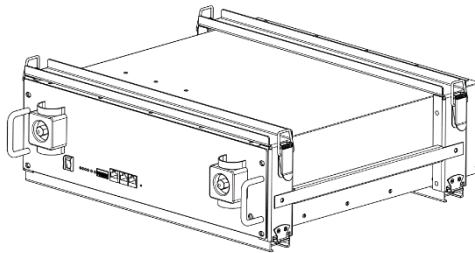

Figure 3-6

4. Stack the required number of battery and bracket combinations as described above, and fasten the upper and lower buckles. Shown as Figure3-7.

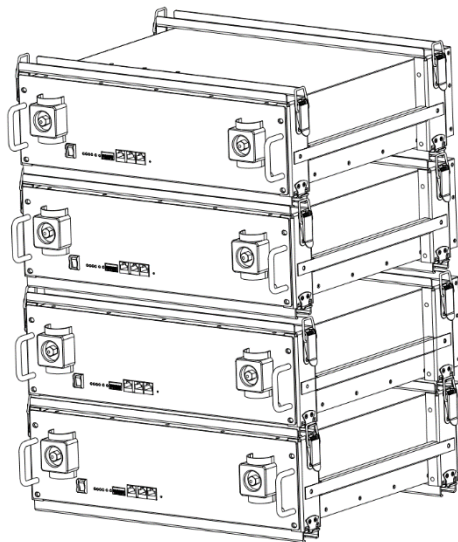

Figure 3-7

3.2.3 Electrical installation

Before connecting the power cables, use multi-meter to measure cable continuity, short circuit, confirm the anode and cathode, and accurately mark the cable labels.

Measuring methods:

- Cable availability: select the buzzer and use the probe to measure the ends of the same color cable. If the buzzer calls, it means the cable is available.
- Short circuit judgment: choose multi-meter resistor file, probe the same end of positive and negative pole, if the resistor shows infinity, it means that the cable is available.
- After visually checking the power cable is in good condition., connect its positive and negative poles respectively to the positive and negative poles of the battery.

It is better to add a circuit breaker between the inverter and the battery system. The selection of the circuit breaker requires:

$$\text{Voltage: } U > 60V$$

$$\text{Current: } I = \frac{\text{Inverter power}}{45V}$$

The circuit breaker is installed between the battery module and the inverter, shown as Figure 3-8:

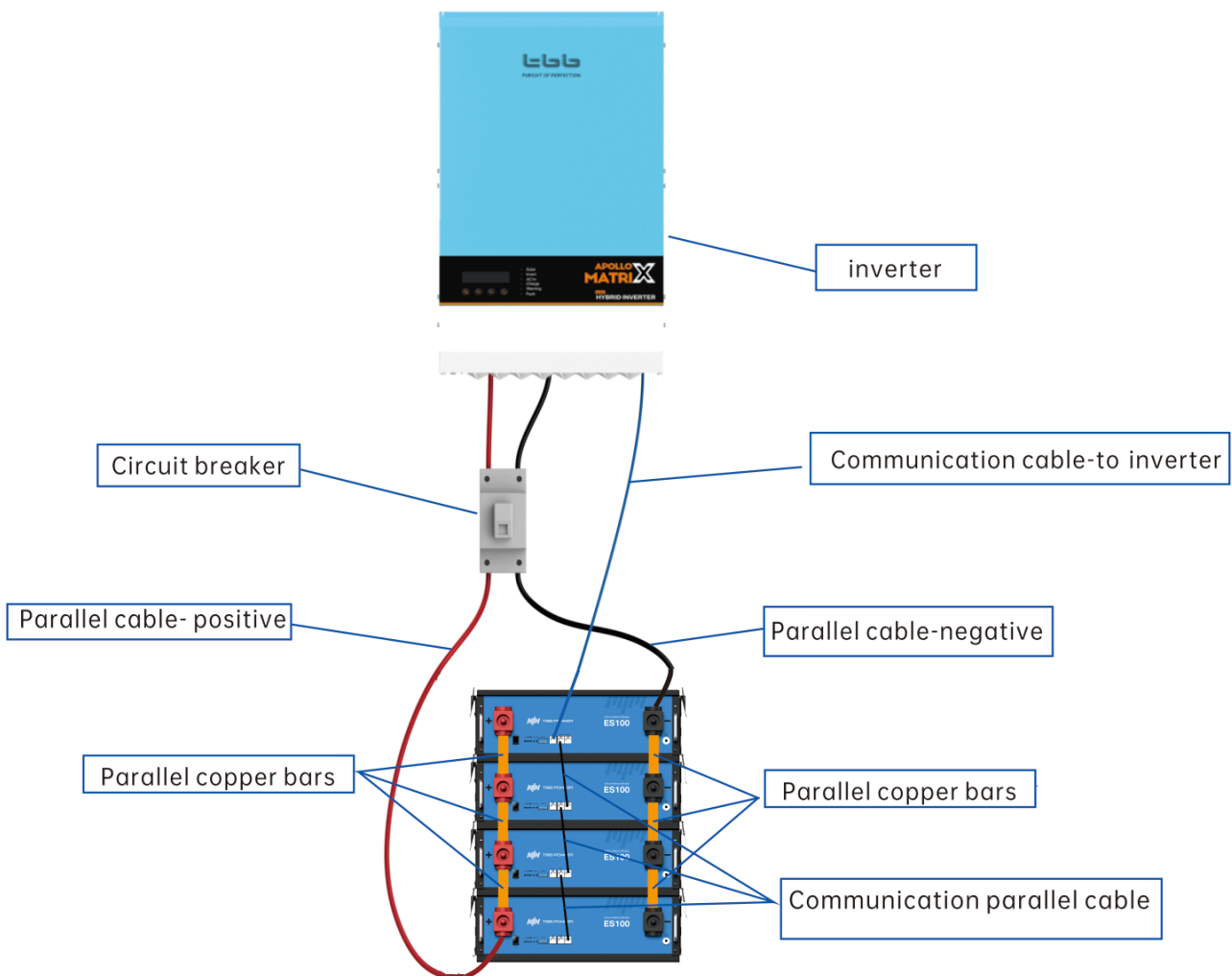

Figure 3-8

4. Use, maintenance and troubleshooting

4.1 Battery system usage and operation instructions

After completing the electrical connection, please follow these steps to start the battery system.

1. Refer to 2.3.2 for the definition of the DIP switch and prepare for the DIP before turning on the system, and then turn the switch ON/OFF to ON.

After the battery indicator completes self-test, the RUN indicator flashes, and the SOC indicator displays according to the current state.

Warning: If there's no response on the battery indicator or the ALM indicator is always on after the above operations, please refer to 4.2 Alarm Description and Handling.

2. Use a voltmeter to measure whether the battery terminal voltage of the circuit breaker is more than 37V, and check whether the voltage polarity is the same as that of the inverter input. If the measured input has a voltage output more than 37V, it means that the battery has started working normally.
3. After confirming the voltage and polarity of the battery, close the circuit breaker and turn on the inverter.
4. Check whether the inverter indicator and battery indicator (communication indicator, status indicator) are normal. If they are normal, complete the connection between the battery and the inverter. If the indicator lights are abnormal, please refer to the inverter instruction manual or contact the dealer.

Table 4-1 Battery and Inverter Power Matching Table

Hybrid Inverter	Off-grid Inverter	ES100	
EPS (backup port) AC Output power	AC Output Power	Min. parallel number	System Energy (kWh)
≤2.5 kW		1	5.04
≤5.0 kW		2	10.08
≤7.5 kW		3	15.12
≤10.0 kW		4	20.16
≤12.5 kW		5	25.2
≤15.0 kW		6	30.24
≤30.0 kW		12	60.48
≤40.0 kW		16	80.64
≤80.0kW		32	161.28

Table4-2

Equipment Use	Charging	a) The battery's long-term continuous charging current should be ≤0.5C b) If the battery capacity is empty, please charge it within 48 hours after the battery is empty.
	Discharging	c)The long-term continuous discharge current of the battery should be ≤1C d)The recommended maximum depth of discharge (DOD) of Battery PACK is no more than 90%.

4.2 Alarm description and handling

When the protection action or fault occurs to the system, the alarm signal will be shown through the working status indicator on the front panel of the battery. The network management can query the specific alarm categories.

If the fault such as single cell overvoltage, charging over-current, under-voltage protection, high-temp protection and other abnormalities affects the output, please deal with it according to

Table4-3

Table 4-3 Main alarm and Protection

Statue	Alarm category	Alarm indication	handling
Charging state	Cell over-voltage	RED	Stop charging and find out the cause of the trouble
	Over-current	RED	Stop charging and find out the cause of the trouble
	High temp	RED	Stop charging
Discharge state	Over-current	RED	Stop discharging and find out the cause of the trouble
	High temp	RED	Stop discharging
	Total voltage Under voltage	RED	Start charging
	Cell voltage under voltage	RED	Start charging

4.3 Analysis and treatment of common faults

Analysis and treatment of common faults in the Table 4-4:

Table 4-4 Analysis and treatment of common faults

No.	Fault phenomenon	Reason analysis	Solution
1	The indicator does not respond after it is powered on	Power switch is broken	Check the power switch
2	The DC power supply time is too short	Battery capacity has become smaller	Storage battery replacement
3	Battery can not be fully charged	Charging voltage is too low	Adjust the charging voltage to 53.5V
4	The power cable sparks once It is powered on and the ALM light turns to RED	Power connection short-circuit	Turn off the battery, check the cause of the short circuit

If you need any technical help or have any questions, please contact the seller in time.

4.4 Recycle and disposal

In case a battery (normal condition or damaged) needs disposal or needs recycling, it shall follow the local recycling regulation (i.e. Regulation (EC) No 1013/2006 among European Union) to process, and using the best available techniques to achieve a relevant recycling efficiency.

TBB POWER CO.,LTD

 service@tbbpower.com

 www.tbbpower.com

 +86-592-5212299

 +86-592-5796070